

Name \_\_\_\_\_

Section \_\_\_\_\_

### PURPOSE

To experimentally demonstrate the characteristics of direct current power supplies.

### EQUIPMENT

#### LAB SUPPLIED PARTS

DC power supply  
DMM

#### PARTS KIT PARTS

Set of meter leads  
Set of clip to clip jumper leads

### INTRODUCTION

- Multiple voltage sources in a series circuit can be replaced with a single voltage source that will have the same effect.

The new supply would have a voltage equal to sum of the individual supplies. (See Figure 1).

In many cases batteries are connected series aiding to achieve a higher voltage.

- When analyzing circuits, ideal supplies that maintain a constant terminal voltage are often used.

However actual supplies like batteries or generators will experience a drop in terminal voltage as the load is increased.

Supplies of this type are often modelled as an ideal supply in series with an internal resistance as shown in Figure #2.

- The fact that a series resistance can cause the load voltage to be reduced can become useful when the supply voltage is too large.

The voltage supplied to a load is sometimes reduced by using a series dropping resistor as shown in Figure #3

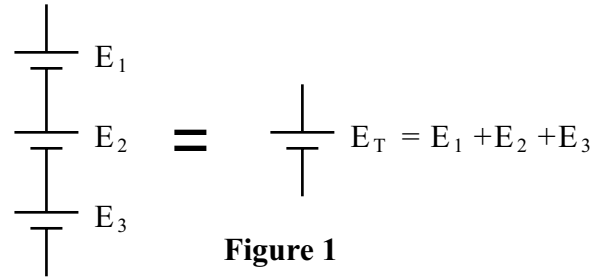

Figure 1

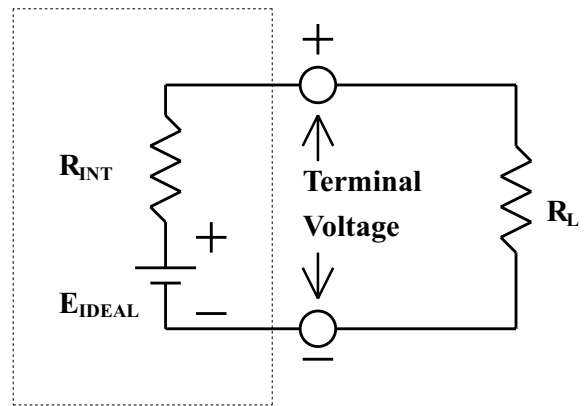

Figure 2

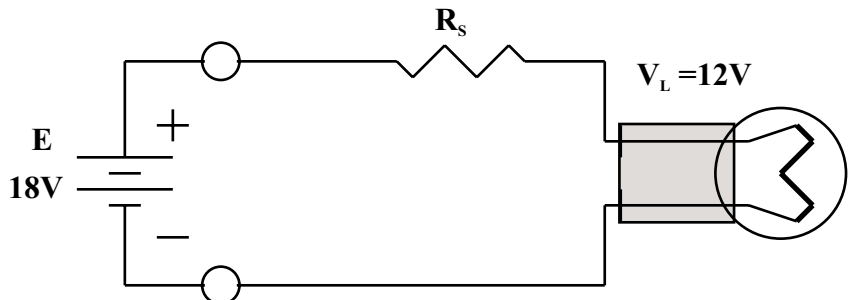
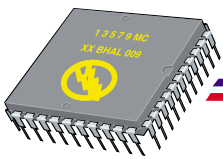

Figure 3



## Lab 4

## dc Power Supplies

### Series Aided Power Supplies

#### PROCEDURE

- 1) Connect the DMM directly across the 1.5 volt battery. Measure the no-load voltage and record it below.

$$E_1 = \underline{\hspace{4cm}}$$

- 2) Use the DMM to set the power supply voltage as close as possible to 5 volts. Record this voltage below. Do not move the power supply controls until procedure #4 has been completed.

$$E_2 = \underline{\hspace{4cm}}$$

- 3) Connect the battery and power supply in a series-aiding configuration as shown in Figure #4. Measure and record the total voltage. The total voltage should be equal to the sum of the voltages. Calculate this value and compare it to the measured value.

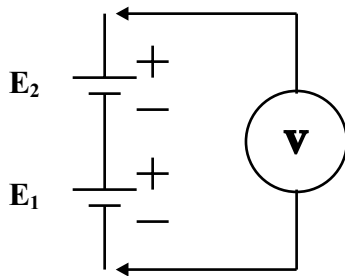

Figure 4

Calculated value of  $E_T$  using the two measured values above.

$$E_{T(\text{calculated})} \underline{\hspace{4cm}}$$

Find the measured value of  $E_T$  by actually measuring the voltage across  $E_1$  and  $E_2$  as shown in Figure4 .

$$E_{T(\text{measured})} \underline{\hspace{4cm}}$$

### Series Opposing Power Supplies

- 4) Reconnect the battery and power supply in a series-opposing configuration as shown in Figure #5. Measure and record the total voltage. The magnitude of the total voltage should be equal to the difference between  $E_1$  and  $E_2$ . Calculate this value and compare it to the measured value.

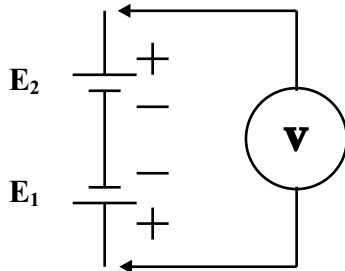

Figure 5

Calculated value of  $E_T$  using the two measured values above.

$$E_{T(\text{calculated})} \underline{\hspace{4cm}}$$

Find the measured value of  $E_T$  by actually measuring the voltage across  $E_1$  and  $E_2$  as shown in Figure5 .

$$E_{T(\text{measured})} \underline{\hspace{4cm}}$$

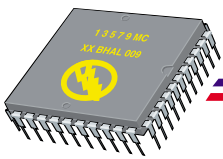

## Lab 4 dc Power Supplies

### The Series Dropping Resistor

In the circuit shown in Figure 6, the supply is 18V.

If it was connected directly across the lightbulb, the bulb would burn out.

We can make the 18 V supply work by adding a resistor.

The idea is to get 12 V across the lightbulb and the other 6 V across the resistor. This will satisfy Kirchoff's voltage law.

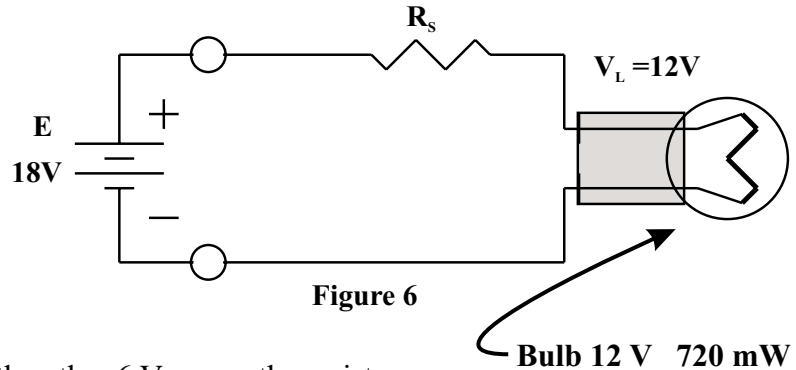

The trick is to select the proper value (and wattage of resistance.)

To find the value of  $R_s$  - do the following

- 1) We know that the lamp has a power of 720 mW. Using this , we can find the current through the lightbulb. Since the resistor is in series with the bulb, the same current will be passing through the resistor.

$P = VI$  and  $I = \frac{P}{V}$  Find I for the lightbulb (show calculation) \_\_\_\_\_

- 2) Now that we know the current in the lightbulb, we can find the proper resistance we need to drop the required 6 volts from the power supply. Use Ohm's Law to find the proper value of resistance.

$R = \frac{V}{I}$  Where: V is the voltage drop across the resistor (6V)  
I is the current through the bulb and resistor

Find R, the value of the resistance (show calculation) \_\_\_\_\_

- 3) The only other thing we need to worry about is the power dissipated by the resistor. If we install a resistor With too low a power rating, the resistor will get hot and burn. The rule of thumb is to calculate the power dissipation and then use the resistor with at least double this rating.

The power rating for the resistor is found using any one of the formulas below. **Find the power dissipated by the resistor using all three of the formulas.** (You should get the same answer for all three.)

$P = VI$  \_\_\_\_\_

$P = \frac{V^2}{R}$  \_\_\_\_\_

$P = I^2R$  \_\_\_\_\_

$P = VI$  Where: V is the voltage drop across the resistor (6V)  
I is the current through the bulb and resistor

$P = \frac{V^2}{R}$  Where: V is the voltage drop across the resistor (6V)  
R is the value of resistance that you calculated above

$P = I^2R$  Where: I is the current through the bulb and resistor  
R is the value of resistance that you calculated above

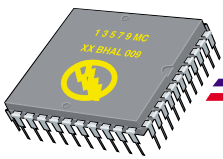

## Lab 4 dc Power Supplies

### The Series Dropping Resistor

The standard wattage of resistors is:  $\frac{1}{8}$  Watt  $\frac{1}{4}$  Watt  $\frac{1}{2}$  Watt 1 Watt 2 Watt 5 Watt 10 Watt And up

Circle the lowest wattage that will do the job (include the safety factor)

*Once you have selected the wattage of the resistor required and you know its value, see the instructor and get the proper value of resistor.*

Build the circuit shown in Figure 6.

Measure the following quantities.

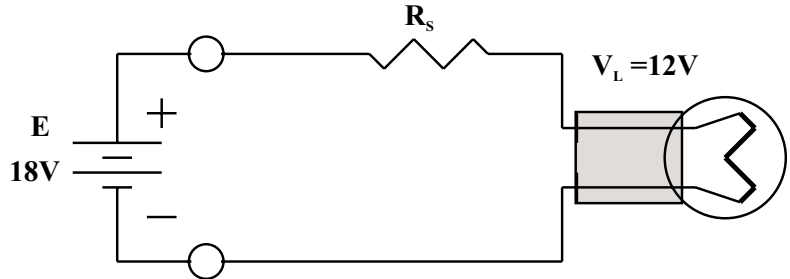

Figure 6

$V_{RS}$  \_\_\_\_\_

$I_T$  \_\_\_\_\_

*These values should reasonably match your calculated values.*

$V_L$  \_\_\_\_\_

$E$  \_\_\_\_\_

**Be careful not to apply the 18 volts directly across the lamp or the lamp will burn out!**

### Electronic Workbench

Load the circuit LAB4 into electronics workbench. You'll find the circuit located on the Web site.

This circuit consists of five components, an 20 volt power supply, and a series voltage dropping resistor, a 10 V 500 milliwatt lamp, an ammeter and a voltmeter. The wires connecting the components have been omitted from the circuit.

Connect the components so the 10 V lamp can be run from the 20 volt supply using the series voltage-dropping resistor. The ammeter and voltmeter should be connected so they measure lamp current and voltage.

The initial value of the series voltage dropping resistance is not correct.

Calculate and record the correct resistance below.

Change the circuit resistance to the calculated value and record the lamp current and voltage.

Calculated resistance of  $R_s$  \_\_\_\_\_  $\Omega$

*Show your calculation here.*

Calculated wattage of  $R_s$  \_\_\_\_\_ mW

What power handling capacity should the resistor be? \_\_\_\_\_

---



---



---



---



---



---



---



---